

Striving to Make Products that Move You

**ORION**

おかげさまで70年  
**70<sup>th</sup>**  
Anniversary

Apr. 2016

R40

Light-Duty Built-In Water Tank Chillers RKS-J Series

Light-Duty  
Built-In Water Tank  
**Chillers**  
RKS-J Series

Mid-Grade Model

**JJM**  
series



Loaded with Application  
Functionality that Conforms  
to Your Operating Environment!

New Model Compact Chiller No. 1 Performer in a Compact Body

COMPACT & POWERFUL

Economy Model

**J**  
series



# Many Functional Specifications Available to Match Your Application

## Factory Options

Factory Option Designation Description

Model : **RKS401J-MV-00000**

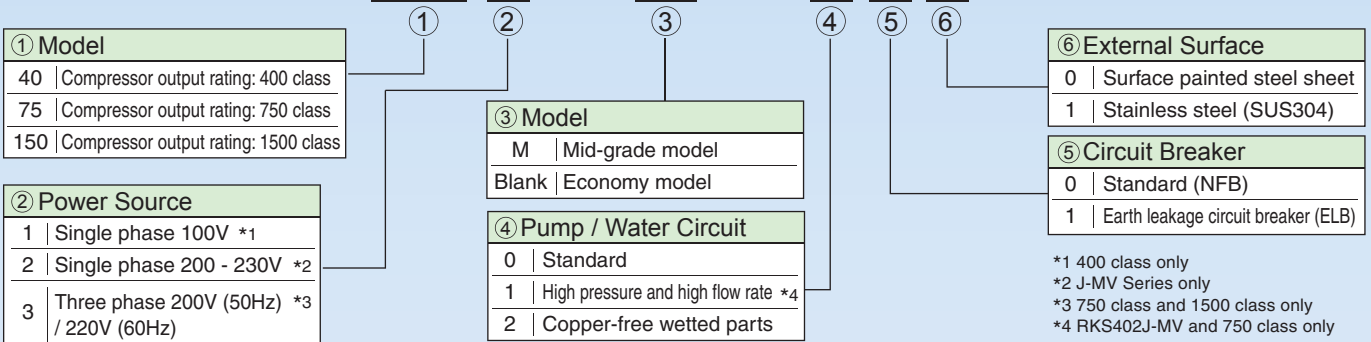

## Accessories

### Remote Communications Interface to Meet Your Various Needs

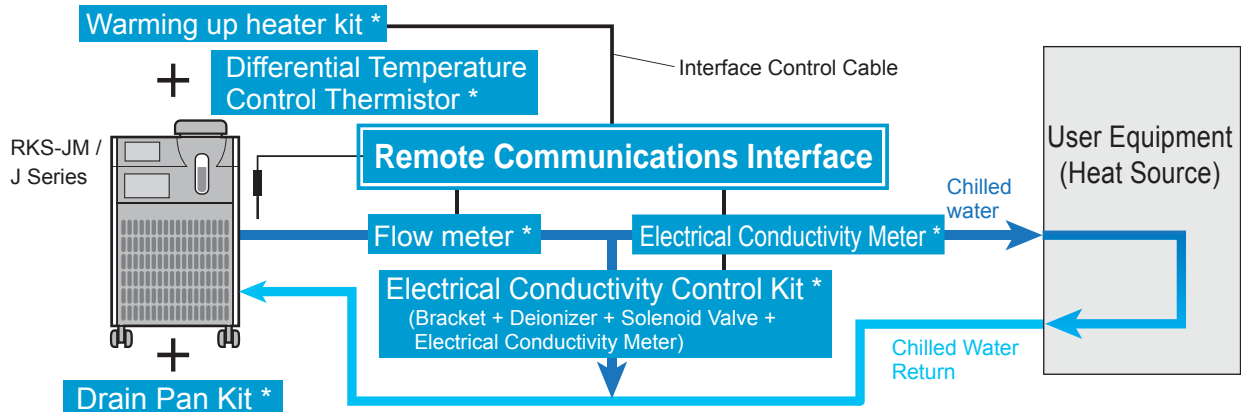

### Choose the Model that Best Suits Your Application

\* Contact us for details.

Model	Name	Qty/Unit	Description
RK-BP001	Bypass Piping Kit A	1	Quick Tube 3/8" Connector
RK-BP002	Bypass Piping Kit B	1	Rc1/2 Pipe
RK-JB001	Compression Fitting	1	Inlet/Outlet 1/2", Brass
RK-VB001	Valve A	1	Inlet/Outlet 1/2", Brass
RK-VB002	Valve B	1	Inlet/Outlet 1/2", SUS
RK-VB003	Valve Kit C	1	Inlet/Outlet 1", Brass
RK-VB004	Valve Kit D	1	Inlet/Outlet 1", SUS
RK-WS001	Automatic Water Supply Kit	1	Float Valve
RK-LV001	Relief Valve Kit	1	Initial Setting: 0.3 MPa (Control range: 0.3 - 0.5 MPa)
RK-FR001	Flow Gauge A *	1	Connected Flow Impeller Type (1.5 - 20 L/min)
RK-FR002	Flow Gauge B *	1	Connected Flow Impeller Type (3 - 60 L/min)
RK-HF001	Water Filter Housing	1	Filter element sold separately
RK-FE001	Filter Element (5 μm)	1	
RK-FE002	Filter Element (10 μm)	1	
RK-FE003	Filter Element (25 μm)	1	
RK-FE004	Filter Element (100 μm)	1	
RK-CA001	Power Cable	1	Single-Phase 200 V Cable Length: 3 m
RK-CA002	Power Cable	1	Three-Phase 200 V Cable Length: 3 m

Model	Name	Qty/Unit	Description
RK-TH001	Differential Temperature Control Thermistor *	1	Cable: 5 m
RK-HI001	Water Startup Heater Kit *	1	Single-Phase 200 V, Capacity: 0.5 kW / for RKS402
RK-HI002	Water Startup Heater Kit *	1	Single-Phase 200 V, Capacity: 1 kW / for RKS75 □
RK-HI003	Water Startup Heater Kit *	1	Single-Phase 200 V, Capacity: 2 kW / for RKS150 □
RK-EB001	Remote Communications Interface	1	Connect external RS422 and RS485 accessories.
RK-DI001	Electrical Conductivity Control Kit A*	1	Bracket, deionizer, solenoid valve, electrical conductivity meter (10 - 500 μS/cm)
RK-DI002	Electrical Conductivity Control Kit B*	1	Bracket, deionizer, solenoid valve, electrical conductivity meter (1 - 20 μS/cm)
RK-DI003	Deionizer Kit	1	Deionizer, valve
RK-DI004	Electrical Conductivity Meter A*	1	Electrical conductivity meter (10 - 500 μS/cm)
RK-DI005	Electrical Conductivity Meter B*	1	Electrical conductivity meter (1 - 20 μS/cm)
RK-RF001	Earthquake Resistance Bracket	1	Painted
RK-DP001	Drain Pan Kit *	1	Drain pan (SUS), float tap
RK-DP002	Drain Pan	1	Drain pan (SUS)
RK-TR001	Transformer Kit	1	Three-phase 380 - 400 V (for three-phase models)
RK-YS001	Y-Strainer Kit A	1	40 mesh 1/2" brass
RK-YS002	Y-Strainer Kit B	1	40 mesh 1/2" SUS
RK-EY001	Eye Bolt Kit	1	Incl. M8x4 rubber washers

\* Items marked with a \* require installation of the RK-EB001 communications interface. ○ A special bypass piping kit is included if the specification is for copper-less wetted parts.

# Made Even Easier to Use!

## Mid-Grade Model J-M Series

RKS401J-MV/ 402J-MV/ 752J-MV/ 753J-MV/ 1502J-MV/ 1503J-MV

High Precision Temperature Control  
+ Inverter Driven High Pressure Pump  
+ High Ambient Temp Compatibility

The electronic expansion valve control achieves  $\pm 0.1^{\circ}\text{C}$  high precision temperature control that translates to increased equipment production accuracy and quality.

Our standard built-in high-pressure pump is inverter driven, thus achieving the same performance specifications even in regions that have different power frequencies.

With an operable ambient temperature range of  $5 - 45^{\circ}\text{C}$  and a broad working liquid temperature range of  $5 - 40^{\circ}\text{C}$ , J-M models can support a wide range of applications.



## Economy Model J Series

RKS753J-V/ 1503J-V

Easy to Use + Simple + Affordable

Compressor ON/OFF control offers temperature control of  $\pm 2^{\circ}\text{C}$  for superior versatility.

High Pressure Pump Built In!

Many options and accessories available on the Mid-Grade line are also available in this series!



## Simple and Reassuring Design on all RKS J (M) Series Models

Simple and reliably designed controller + substantial functionality

Easy operation with just the flick of a switch!  
Alarm details via error code display for quick recovery.

### Output Signals

- Operation Signal
- Alarm Signal
- Remote Signal

### Operating Modes

- Freeze-Prevention Mode
- Warm Up Mode
- Discharge Pump-Only-Operation
- Automatic Recovery After Power Outage, etc.

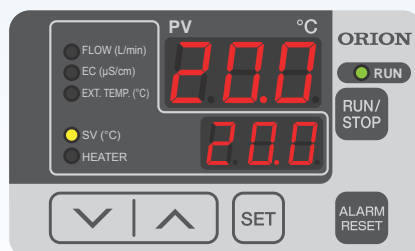

Large Capacity Tank with Wide Water Supply Port

$\phi 100$  mm large water supply port for easy cleaning! The high capacity tank means less frequent water shortage warnings, less frequent water supplying, and less change in water temperature due to changing loads. A built-in blue LED lit water indicator for easy confirmation of water level!



Wide mouth water supply port for easy tank cleaning.



Easy to check LED lit water level gauge.

# Specifications Chart: Standard Models

Model		RKS-JM Series						RKS-J Series					
		401J-MV	402J-MV	752J-MV	753J-MV	1502J-MV	1503J-MV	753J-V	1503J-V				
Performance Specifications	Cooling Capacity (50Hz/60Hz) *1	kW		1.3/1.5		2.2/2.5		4.9/5.3		2.2/2.5		4.9/5.3	
	Heating Capacity (50Hz/60Hz) *1	kW		0.53/0.53		0.6/0.6		1.1/1.1					
	Operable ambient temperature range	°C		5~45						10~40			
	Operable fluid temperature range	°C		5~40						15~35			
	Operating Water Pressure	MPa		0.05~0.3			0.1~0.6			0.05~0.3		0.1~0.5	
	Control accuracy *4	°C		±0.1						±2.0			
	Operating flow rate (50Hz/60Hz)	L/min		10 (Head30m)			18 (Head60m)			10 (Head20/30m)		12/21 (Head50m)	
Power Specifications	Power Source *2	V (Hz)		Single-phase 100 (50/60Hz)	Single-phase 200~230 (50/60Hz)		Three-phase 200 (50/60Hz) · 220 (60Hz)	Single-phase 200~230 (50/60Hz)	Three-phase 200 (50/60Hz) · 220 (60Hz)	Three-phase 200 (50/60Hz) · 220 (60Hz)			
	Power consumption (50Hz/60Hz) *1	kW		0.8/0.7	0.9/1.0	1.1/1.2	0.9/1.0	2.0/2.5	1.8/2.2	0.9/1.1	1.8/2.2		
	Electric current (50Hz/60Hz) *1	A		7.9/7.3	3.8/4.7	5.2/5.4	3.6/3.4	7.6/8.5	6.6/8.2	4.1/4.1	6.8/7.4		
	Power capacity *3	kVA		1.2	1.5	2.0	2.0	4.2	4.2	2.0	4.2		
	Breaker capacity *5	A		15	10	15	10	30	15	10	15		
Operation control method		Electronic expansion valve capacity control											
Equipment Details	Compressor	kW		Fully sealed rotary type									
				0.55	0.6	0.75	0.85	1.2	1.8	0.85	1.8		
	Condenser		Corrugated fin and tube parallel flow type										
	Heat exchanger	Construction		Plate type heat exchanger									
		Material		SUS316 (Brazing: Cu)									
	Discharge pump	Construction		Cascade type									
		Output	kW		0.25 (Inverter driven)			0.4 (Inverter driven)			0.25	0.4	
	Water tank capacity		L		approx.17								
	Refrigerant		R-410A										
	Outside dimensions (H × D × W)		mm		615 × 500 × 375			933 × 590 × 375			615 × 500 × 375	933 × 590 × 375	
Unit mass (dry weight)		kg		42		47		68		47	68		

\* 1, Operating conditions: Chilled water temp. : 20°C , Ambient temp. : 25°C . Cooling capacity is at least 95% of listed figures. Heating capacity will differ depending on operating conditions.  
 \* 2, Source voltage phase unbalance should be less than ± 3%. \* 3, The figure noted is when operating at the highest capacity in the normal operating range. \* 4, Continuous current load fluctuation within ± 10%, and with stable ambient temp. However does not include starting times or when the heat-load exceeds the chiller capacity. \* 5, Unit comes with a built-in overload protection breaker: NFB. Note 1: Working fluid should be either clean water or a 40% or lower concentrated solution of industrial-use ethylene glycol. Note 2: Heat output from the unit (in kW) is approx. 1.3 times that of the cooling capacity. Note 3: Depending on the operating environment, condensation may form on piping inside the product, and temporary leakage of water from the pump mechanical seals may also occur, therefore a drain pan should be installed if required.

## External Dimensions(mm)

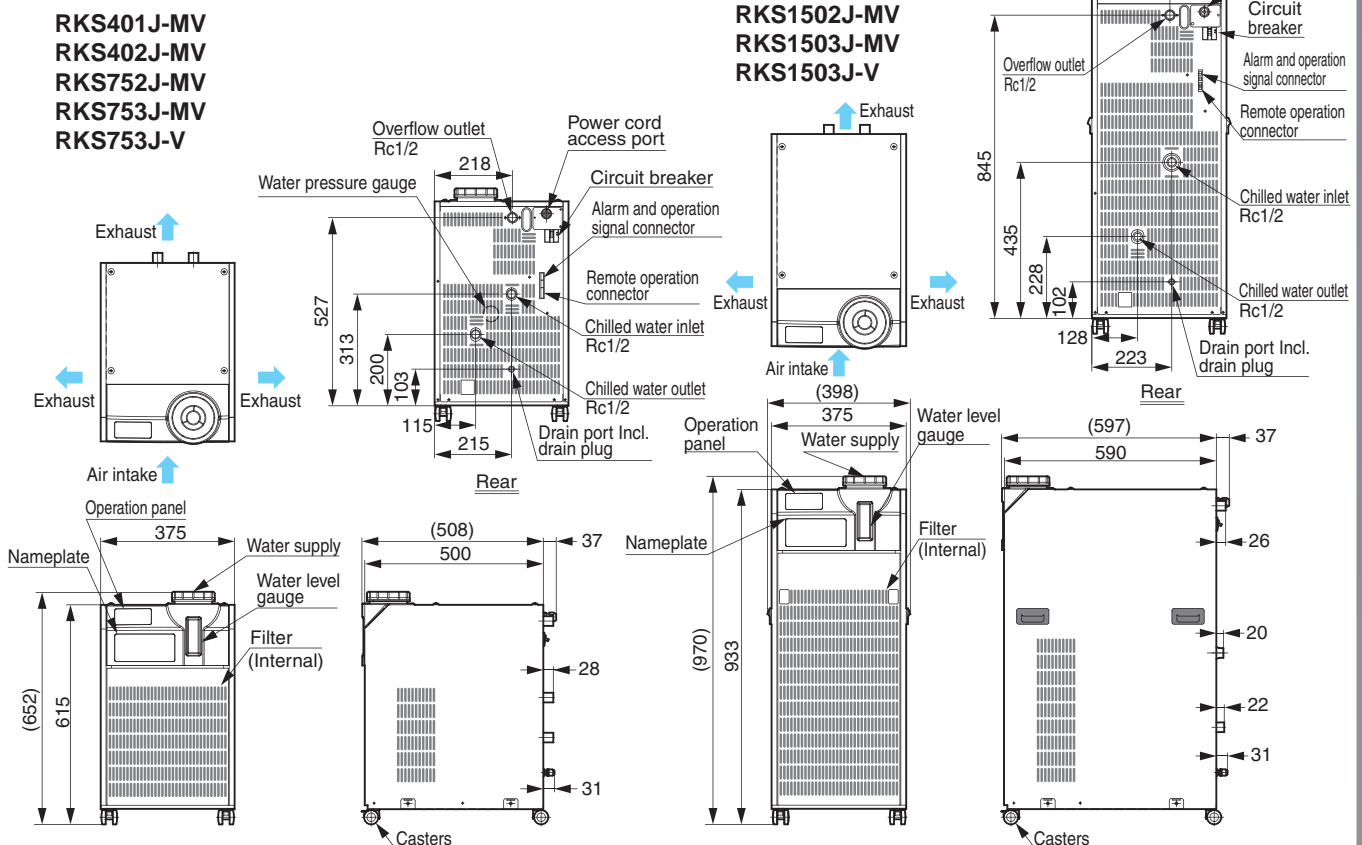

\* Piping connection dimensions noted in drawings have a maximum tolerance of ±3mm.



# Chilled Water Flow Chart

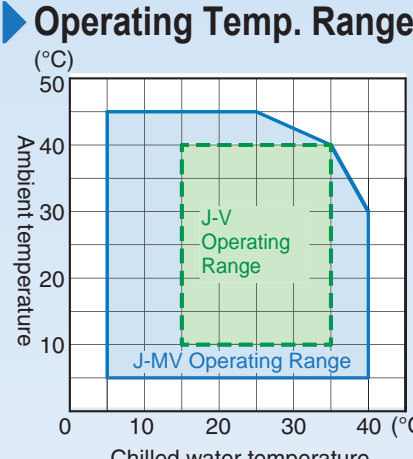
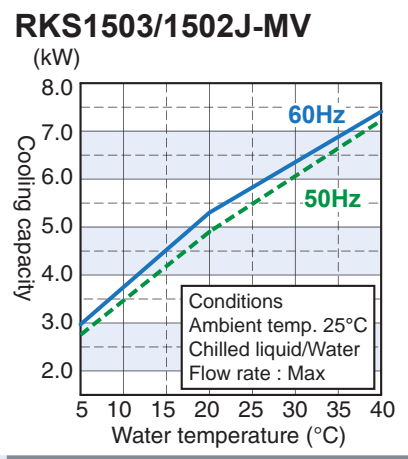
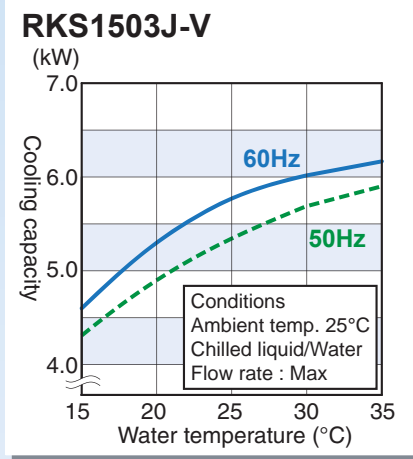
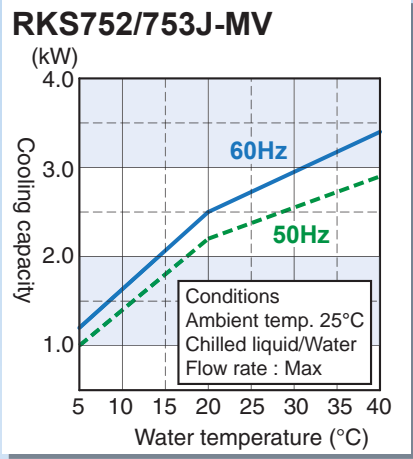
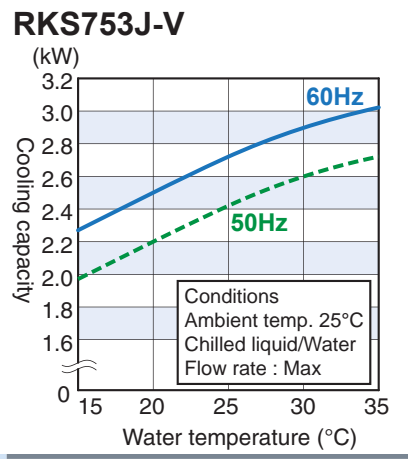
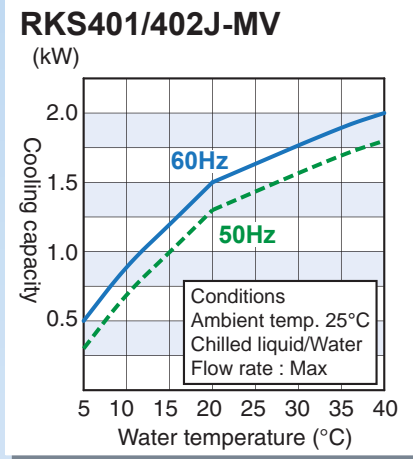

## Discharge Pump Characteristic Curves

\*1: Refer to 60Hz curve. \*2: Refer to 50/60Hz curve.

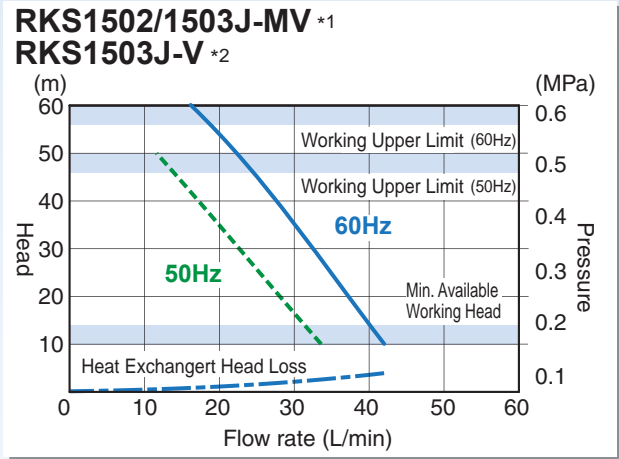
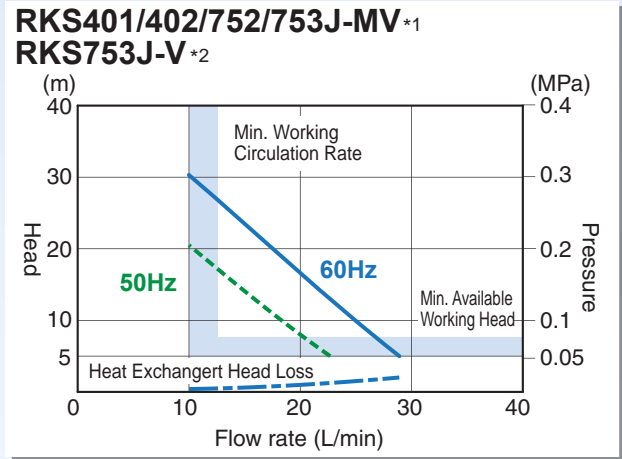

## Discharge Pump Characteristic Curves (For factory options)

\*1: Refer to 60Hz curve. \*2: Refer to 50/60Hz curve.

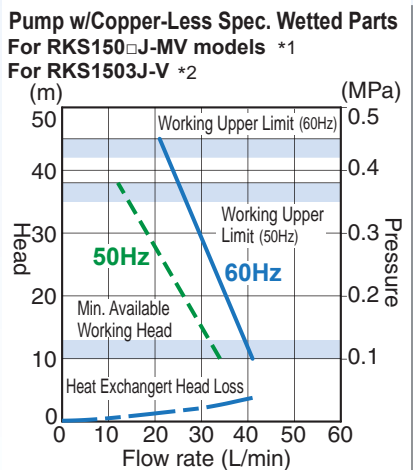
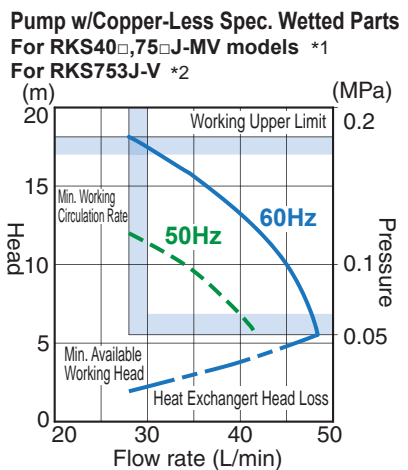
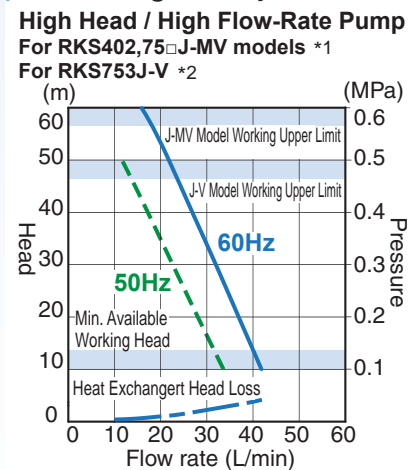

# Useful in a Wide Range of Applications



Welding Machine



UV Laser Engraving Machine



Packaging Machinery



Laboratory Furnace/Kiln



Jacket Cooling



Concentrating Equipment



Analysis Equipment



X-Ray Inspection Equipment

## Also Invaluable in Many Other Fields

- Sputtering Equipment · Deposition Equipment · Vacuum Reflow Oven · Marking Equipment
- Photolithography Equipment · Turbomolecular Pump · Dispenser · Electron Microscope (SEM, TEM)
- Gas Chromatograph · Magnetizing Equipment · EB Equipment · Printing Equipment
- Bag Manufacturing Equipment · Mill · Grinding Machine, etc.



### Safety Precautions

- Consult with a qualified professional or your ORION dealer for product installation and wiring.
- Please select a product that is suitable for the desired application. Do not use for other than intended purposes. Use for other than intended purposes can lead to accidents or product breakdown.
- This product is designed and produced as a commodity for general manufacturing. Accordingly, the warranty does not apply to nor does it cover the following applications. However, in cases where the customer/user takes full responsibility and confirms the performance of the product in advance, and takes necessary safety precautions, please consult with ORION and we will consider if use of the product in the desired application is appropriate.
  - ① Atomic energy, aviation, aerospace, railway works, shipping, vehicles (cars and trucks), medical applications, transportation applications, and/or any applications where it might have a great effect on human life or property.
  - ② Electricity, gas, or water supply systems, etc. where high levels of reliability and safety are demanded.

ORION Machinery Co., Ltd  
is ISO Certified in Quality Assurance and Environmental Management.



ISO 9001  
ISO 14001 Certified (Head Office Factory)



## ORION MACHINERY CO., LTD.

International Group 246, Kotaka, Suzaka-shi, Nagano-ken, 382-8502 Japan  
TEL +81-(0)26-246-5664 FAX +81-(0)26-246-6753  
Email: kokusai@orionkikai.co.jp

Head Office & Factory 246, Kotaka, Suzaka-shi, Nagano-ken, 382-8502 Japan  
TEL +81-(0)26-245-1230 FAX +81-(0)26-245-5424  
URL: <http://www.orionkikai.co.jp>

This catalogue contains product specifications as of Apr. 2016.

- Actual product colors may vary slightly from catalogue.
- The structure or specifications of products contained in this catalogue are subject to change without prior notice.